

# CW20 / 20S GPS Receiver

## Description

The CW20 is a compact, powerful GPS tool that builds on NavSync's position as a market leader in the field of low signal strength GPS tracking. Utilizing a new baseband processor and RF front end, the CW20 delivers superior GPS performance in small surface mount package that minimizes power consumption, maximizing battery life.

The CW20 takes up only 21 x 16.4 mm of PCB space and connects directly to the host system through a UART using NMEA protocols. Additionally, the device provides expanded protocols for enhanced performance and flexibility. The device has been specifically developed for mobile hardware platforms running off batteries, where power consumption and small size are critical. Unlike many other options in this space, the CW20 delivers enhanced GPS tracking, down to -152 dBm, enabling tracking in many obstructed view environments such as urban canyons.



*This document provides information on the Hardware Elements of the CW20 / 20S. Unless explicitly stated, CW20 is generically used for both the CW20 and CW20S (SBAS enabled) models.*

## Features

- Supports either active or passive antenna
- Low power consumption: 19 mA avg fully active
- Compact design: 21 x 16.4 x 2.4 mm
- Support of WAAS/EGNOS

## Applications

- Battery Powered Devices
- Navigation
- Vehicle tracking
- Asset tracking
- Personnel tracking
- Location Based Services
- Security
- Surveying

## SPECIFICATIONS

### Performance

#### Physical

Module Dimensions	21mm (D) x 16.35mm (W) x 2.4mm (H)	Notes
-------------------	------------------------------------	-------

#### Electrical

Supply Voltages	3V3 (NVDD), 1V5 (VBAT)	1
-----------------	------------------------	---

Operating Temperature Range	-30°C to 65°C
-----------------------------	---------------

Storage Temperature Range	-40°C to 85°C
---------------------------	---------------

#### GPS Performance

GPS Channels	16
--------------	----

Frequency	1575.42 MHz – L1 C/A Code
-----------	---------------------------

TTF Cold Start @ -135 dBm	46 seconds	2, 8
---------------------------	------------	------

TTF Warm Start @ -141 dBm	34 seconds	2, 8
---------------------------	------------	------

TTF Hot Start @ -141 dBm	5 seconds	2, 8
--------------------------	-----------	------

Re-acquisition time @ -147 dBm	<3 seconds	3
--------------------------------	------------	---

Acquisition Sensitivity (fix not available)	TTF (Hot) with all signals at -138 dBm: 30 s TTF (Hot) with all signals at -141 dBm: 41 s	4
---	--	---

Acquisition Sensitivity (fix available) (dBm)	-147 dBm	5
---	----------	---

Tracking Sensitivity (dBm)	-150 dBm	6
----------------------------	----------	---

Acquisition Sensitivity SBAS Satellites (dBm)	-135 dBm	7
---	----------	---

Tracking Sensitivity SBAS Satellites (dBm)	-143 dBm	7
--	----------	---

Static Accuracy (without SBAS)	50% Confidence (CEP)	1.2 m	8
	95% Confidence	3.1 m	

Static Accuracy (with SBAS)	50% Confidence (CEP)	0.8 m	9
	95% Confidence	2.0 m	

Maximum Horizontal Speed	515 m/s	10
--------------------------	---------	----

Maximum Vertical Speed	15 m/s	11
------------------------	--------	----

Maximum Altitude	18 Km	12
------------------	-------	----

Maximum Acceleration (g)	2 g
--------------------------	-----

#### Power

During acquisition (fully active)	69 mW
-----------------------------------	-------

While tracking (fully active)	56 mW
-------------------------------	-------

During Sleep Mode (NVDD)	1.3 mA
--------------------------	--------

VBAT Current	4 µA
--------------	------

#### Interfaces

I/O Port	UART
----------	------

Protocols	NMEA 0183
-----------	-----------

#### Antenna (pin 16 or 26)

Configuration Supported	Active or Passive	13
-------------------------	-------------------	----

Impedance	50Ω
-----------	-----

Voltage	2.5 - 2.8V	14
---------	------------	----

1 dB Compression Point	-31 dBm	15
------------------------	---------	----

### General Specifications

#### Notes:

1. Typical listed are maximum, see Section 2.3 for Absolute Max Ratings
2. These are RMS values
3. Maximum Sensitivity -147 dBm
4. Simulator Test, all signals at specified power level.
5. Estimated
6. Simulator Test, continuous fix with all signals at specified power level.
7. Simulator Test with signal at specified power level.
8. Open-sky, 24 hrs statistic, active antenna (signal range is between 30 to 49 dB/Hz).
9. Open sky, 24 hrs statistic, active antenna (EGNOS signal used).
10. Limited by International Traffic in Arms Regulation (ITAR)
11. Defined by navigation integrity check
12. Limited by International Traffic in Arms Regulation (ITAR)
13. Either pin 16 or pin 26 may be used, but not both
14. Specification apply to active antenna configuration. A 15Ω current sense resistor is included in the on-board antenna sense circuitry which drops the available antenna voltage linearly to 2.5V if 20 mA is drawn by the antenna.
15. Input referred to antenna input at pin 16 or 26.

## Electrical Characteristics

Symbol	Condition	Min	Max	Units	Notes
NVDD		3.0	3.6	Volts	
VBAT		1.2	2.0	Volts	1
VIH		1.26		V	2
VIL			0.3	V	2
VOH	I <sub>OH</sub> = -50uA	1.62		V	2
VOL	I <sub>OL</sub> = 50uA		.18	V	2
Output Rise Time	Cl <sub>oad</sub> = 15 pF		5	ns	
Output Fall Time	Cl <sub>oad</sub> = 15 pF		5	ns	

**Table 2: Electrical Characteristics**

**Notes:**

1. A means to limit charge voltage below 2V should be included if the battery can be removed while the main power is on.
2. Digital Inputs and Outputs are 1.8V CMOS.

## Absolute Maximum Ratings

Parameter	Max
Max Supply Voltage, NVDD	6V
Max Supply Voltage, VBAT	2.2V
Max Voltage on any pin	2.1V
Max current into any pin (except NVDD and VBAT)	±20 mA

**Table 3: Absolute Maximum Ratings**

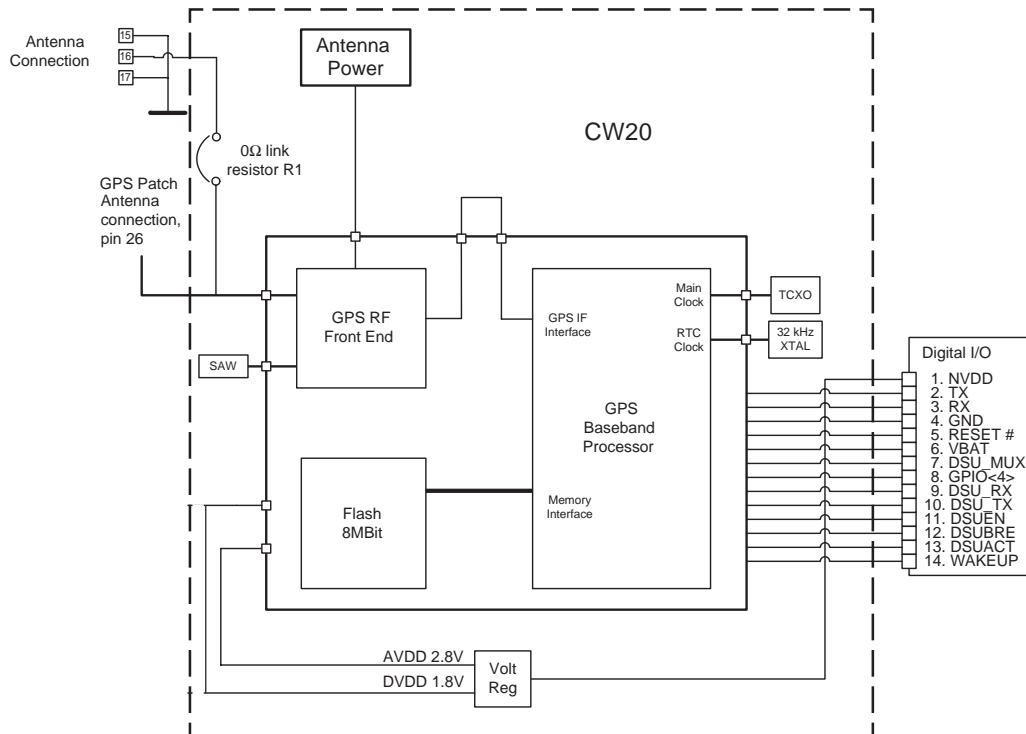

**CW20 Block Diagram**

# CW20 GPS Receiver



## PHYSICAL CHARACTERISTICS

### Physical Interface Details

The interface to the CW20 is via 0.90 mm castellations on a 1.27 mm pitch. There are 25 castellations in all, along with an additional patch antenna connection (pin 26, See Figure 2) for direct connection of a ceramic patch antenna. If pin 26, rather than pin 16, is used as the antenna connection, it is recommended to remove R1 (shown in figure 2). The details of the interface connections are given below.

Pin	Function	Pin	Function
1	NVDD	14	WAKEUP
2	TX	15	GND
3	RX	16	ANT
4	GND	17	GND
5	RESET #	18	GND
6	VBAT	19	GND
7	DSU_MUX	20	GND
8	GPIO <4>	21	GND
9	DSU_RX	22	GND
10	DSU_TX	23	GND
11	DSUEN	24	GND
12	DSUBRE	25	GND
13	DSUACT	26	ALT_ANT

Table 4: PIN Assignments

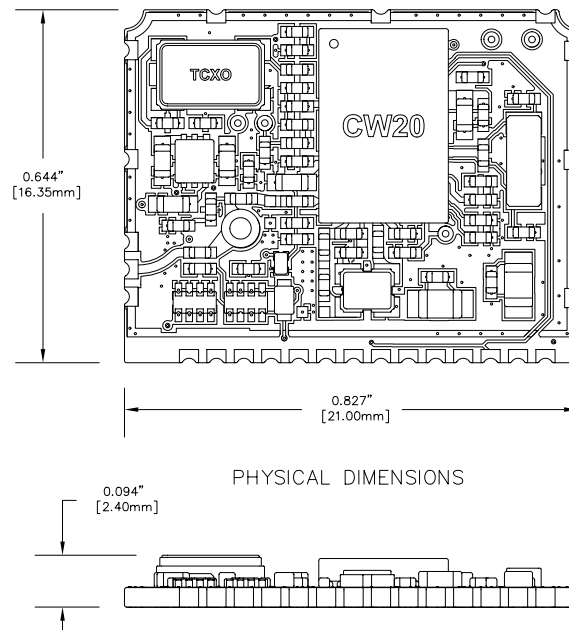

Mechanical Dimensions

### NavSync, Ltd. Headquarters

Bay 143  
Shannon Industrial Estate  
Shannon, Co. Clare, Ireland  
Phone: +353 61 475 666  
E-mail: [sales@navsync.com](mailto:sales@navsync.com)

### In North America

2111 Comprehensive Drive  
Aurora, IL 60505, USA  
Phone: 630.236.3026  
E-mail: [northamerica@navsync.com](mailto:northamerica@navsync.com)  
[www.navsync.com](http://www.navsync.com)