

CW45A GPS Sensor

Description

The CW45A GPS sensor is a fully integrated module that includes the CW25 GPS receiver, DC/DC converter, RS232, RS422 and USB interface options, and active GPS antenna — all housed in a small weatherproof (IP67 rated) enclosure.

The CW25 GPS receiver, at the center of the CW45A sensor, has been designed specifically for acquiring and tracking satellites in weak signal areas such as under dense foliage, severe urban canyons and even inside buildings.

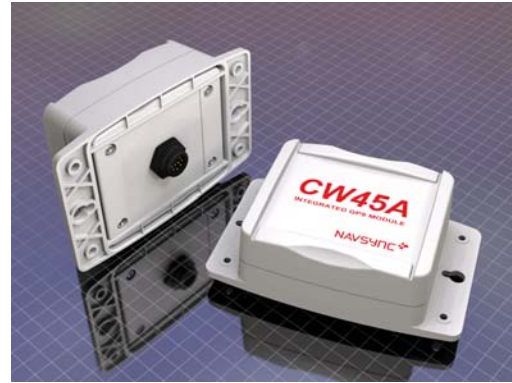

Applications

- Synchronization
- Timing
- In-Building Timing
- Urban Canyon Installations
- Remote Site Locations

The CW45A can acquire satellites at signal levels down to -155dBm with network assisted ephemeris data, and track satellites down to -155dBm . The CW45A can also autonomously acquire satellites at signal levels as low as -143dBm

The CW45A can also continue to provide synchronization in very weak signal areas including inside buildings; which will dramatically reduce installation costs. *For example; many environments require high placement (i.e 40 ft.) of the GPS antenna to ensure a clear view of satellites.* The CW45A eliminates this need and cost through its low signal strength tracking capabilities.

Block Diagram

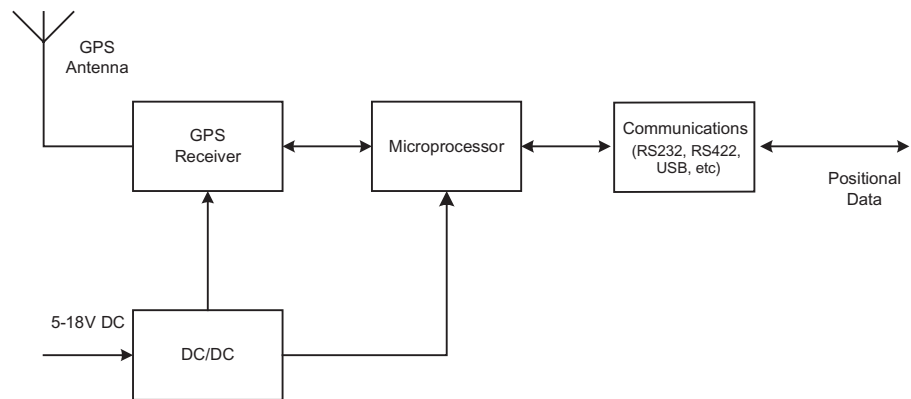

CW45A GPS SENSOR SPECIFICATIONS

SPECIFICATIONS¹

Physical	Module dimensions	101mm (length) x 91mm (width) x 43mm (height)
	Module Rating	IP67
	Supply voltage	5-18V DC
	Operating / Storage Temp	-40°C to +75°C / -55°C to +125°C
	Humidity	5% to 95% non-condensing
	Max Velocity / Altitude	515ms ⁻¹ / 18,000m
	Max Acceleration / Jerk	4g / 1gs ⁻¹ (sustained for less than 5 seconds)
Sensitivity	Acquisition/Tracking	-185dBW / -185dBW
Acquisition Time	Hot Start with network assist	Outdoor <2s Indoor (-185dBW): <5s
	Stand Alone (Outdoor)	Cold: <45s
		Warm: <38s
		Hot: <5s
		Re-acquisition: <0.5s (90% confidence)
Accuracy	Position: Outdoor / Indoor	<5m rms / <50m rms
	Velocity	<0.05ms ⁻¹
	Latency	<200ms
	Raw Measurement Accuracy	Pseudorange <0.3m rms, Carrier phase <5mm rms
	Tracking	Code and carrier coherent
Power	1 fix per second	0.6W typically (dependant of software build)
	Sleep/Standby Current	1mA/1uA
Interfaces	Serial	RS232, RS422 and USB programmable baud rate up to 38400
	Protocols	Network Assist, NMEA 0183, Proprietary ASCII and binary message formats
	Event Input	30ns rms accuracy, <10ns resolution
	Receiver Type	12 parallel channel x 32 taps up to 32 point FFT. Channels, taps and FFT can be switched off to minimize power or simulate simpler designs.
General	Processor	ARM 966E-S on a 0.18 micron process at up to 120 MHz.

CW45A-RS232 CABLE DIAGRAM

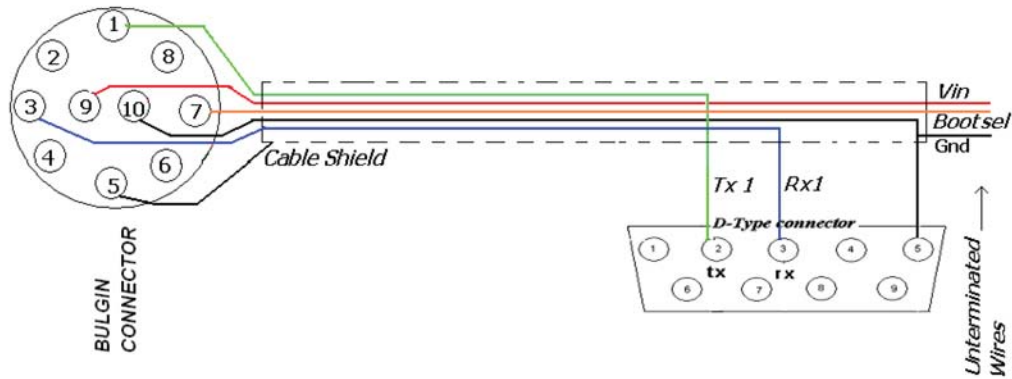

Pin	Name	I/O	Description
1	TXD	O	NMEA 0183 output from GPS Core, Refer to CW25 User Manual for description of proprietary messages. The Baud rate is up to 38400 and the default is 38400.
3	RXD	I	NMEA 0183 input to GPS Core. Refer to CW25 User Manual for description for proprietary commands.
5	GND	PWR	Cable shield GND.
7	BOOTSEL	I	Boot Select pin allows Firmware to be upgraded when pulled low (i.e. tie to Gnd Wire before power-up).
9	VCC	PWR	Voltage Supply Input. 5V - 18V DC to be supplied here.
10	GND	PWR	Power supply return to ground.

CW45A-RS232 CABLE OVERVIEW & SETUP INSTRUCTIONS

Setup Instructions

Place the CW45A where it has a good view of the sky.

1. Attach Bulgin Data Connector to CW45A.
2. Connect RS232 Socket to PC.
3. Apply Power Supply Voltage between the Red (+ive) and Black (-ive) unterminated wires.
4. Data should start to stream.
5. Wait for GPS lock.





CW45A GPS Sensor

NavSync Ltd. Headquarters

*Bay 143
Shannon Industrial Estate
Shannon, Co. Clare, Ireland
Phone: +353 61 475 666
E-mail: sales@navsync.com*

In North America

*2111 Comprehensive Drive
Aurora, IL 60505, USA
Phone: 630.236.3026
E-mail: northamerica@navsync.com
www.navsync.com*