

CW46 GPS Sensor

Description

The CW46 GPS sensor is a fully integrated module that includes the CW25 GPS receiver, DC/DC converter, RS232, RS422 and USB interface options, and active GPS antenna — all housed in a small weatherproof (IP67 rated) enclosure.

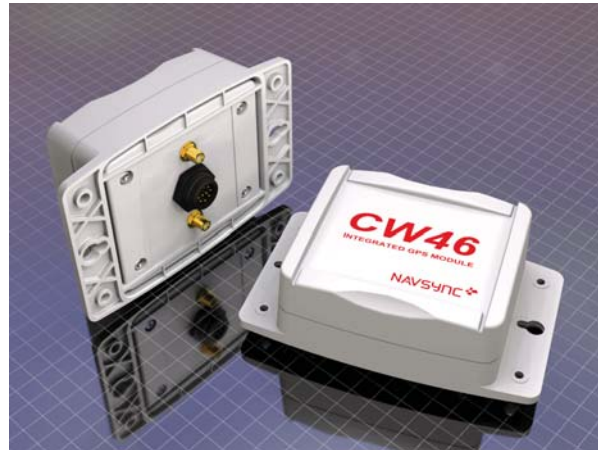

The CW25 GPS receiver, at the center of the CW46 sensor, has been designed specifically for acquiring and tracking satellites in weak signal areas such as under dense foliage, severe urban canyons and even inside buildings.

The CW46 can acquire satellites at signal levels down to -155dBm with network assisted ephemeris data, and track satellites down to -155dBm . The CW46 can also autonomously acquire satellites at signal levels as low as -143dBm

The CW46 utilizes the CW25-TIM GPS receiver inside, allowing the CW46 to act as a complete timing module capable of outputting a GPS disciplined frequency up to 10 MHz that can achieve full PRC MTIE performance in good signal areas.

The CW46 can also continue to provide synchronization in very weak signal areas including inside buildings; which will dramatically reduce installation costs. *For example; many environments require high placement (i.e 40 ft.) of the GPS antenna to ensure a clear view of satellites.* The CW46 eliminates this need and cost through its low signal strength tracking capabilities.

Applications

- Synchronization
- Timing
- In-Building Timing
- Urban Canyon Installations
- Remote Site Locations

Block Diagram

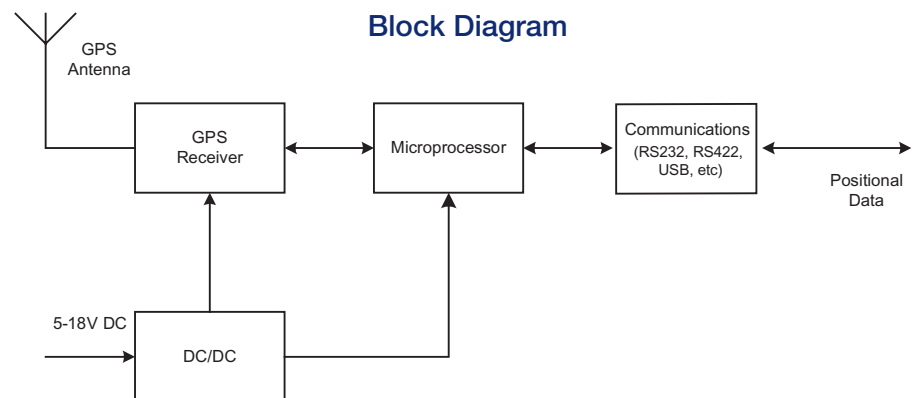

CW46 GPS SENSOR SPECIFICATIONS

SPECIFICATIONS¹

Physical	Module dimensions	101mm (length) x 91mm (width) x 43mm (height)
	Module Rating	IP67
	Supply voltage	5-18V DC
	Operating / Storage Temp	-40°C to +75°C / -55°C to +125°C
	Humidity	5% to 95% non-condensing
	Max Velocity / Altitude	515ms ⁻¹ / 18,000m
	Max Acceleration / Jerk	4g / 1gs ⁻¹ (sustained for less than 5 seconds)
Sensitivity	Acquisition/Tracking	-185dBW / -185dBW
Acquisition Time	Hot Start with network assist	Outdoor <2s
		Indoor (-185dBW): <5s
	Stand Alone (Outdoor)	Cold: <45s
		Warm: <38s
		Hot: <5s
		Re-acquisition: <0.5s (90% confidence)
Accuracy	Position: Outdoor / Indoor	<5m rms / <50m rms
	Velocity	<0.05ms ⁻¹
	Latency	<200ms
	Raw Measurement Accuracy	Pseudorange <0.3m rms, Carrier phase <5mm rms
	Tracking	Code and carrier coherent
Power	1 fix per second	0.6W typically (dependant of software build)
	Sleep/Standby Current	1mA/1uA
Interfaces	Serial	RS232, RS422 and USB programmable baud rate up to 38400
	Protocols	Network Assist, NMEA 0183, Proprietary ASCII and binary message formats
	1pps Timing Output	30ns rms accuracy, <5ns resolution
	Event Input	30ns rms accuracy, <10ns resolution
	Frequency Output	10 Hz to 10 MHz
	Receiver Type	12 parallel channel x 32 taps up to 32 point FFT. Channels, taps and FFT can be switched off to minimize power or simulate simpler designs.
	General	Processor

CW46 GPS MTIE PERFORMANCE

The graph below demonstrates the MTIE performance of the CW46 output frequency relative to a Caesium atomic clock, with the CW46 operating with a clear view of the sky.

MTIE: Fo=10.00 MHz; Fs=1.000 Hz; 11/19/03 05:45:08 PM, 11/20/03 09:08:18 AM,
HP 53132A: Test 545; 10 MHz NCO; Samples: 55388; Gate: 1 s; Ref ch2: 10.00 MHz; TI/Time Data Only; TI 1>2

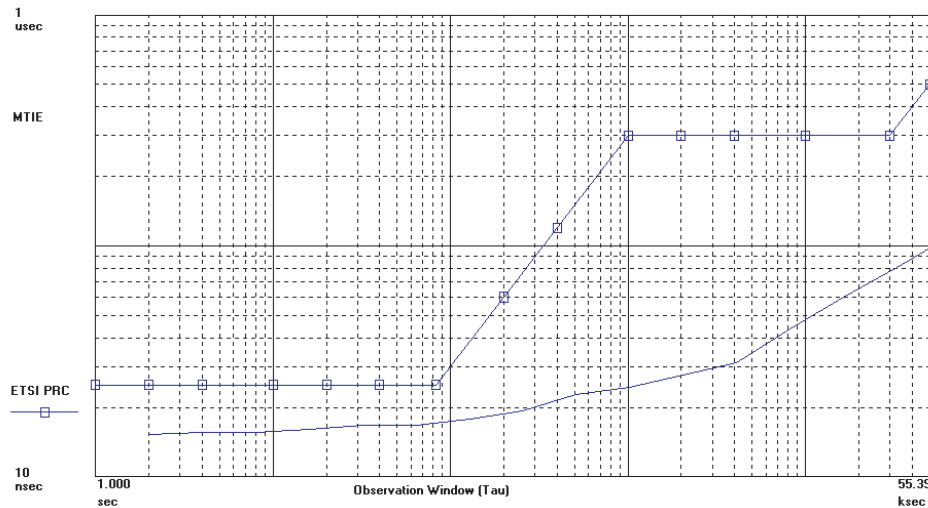

The graph below demonstrates the ability of the CW46 to continue to provide a GPS disciplined output frequency with the GPS aerial located completely inside a building (the degradation of MTIE performance is due to the effects of signal multi-path)

MTIE: Fo=10.00 MHz; Fs=999.0 MHz; 2/12/04 02:38:18 PM, 2/12/04 05:50:27 PM,
HP 53132A: Test 589; CW25_indoor_tim; Samples: 11506; Gate: 1 s; Ref ch2: 10.00 MHz; TI/Time Data Only; TI 1>2

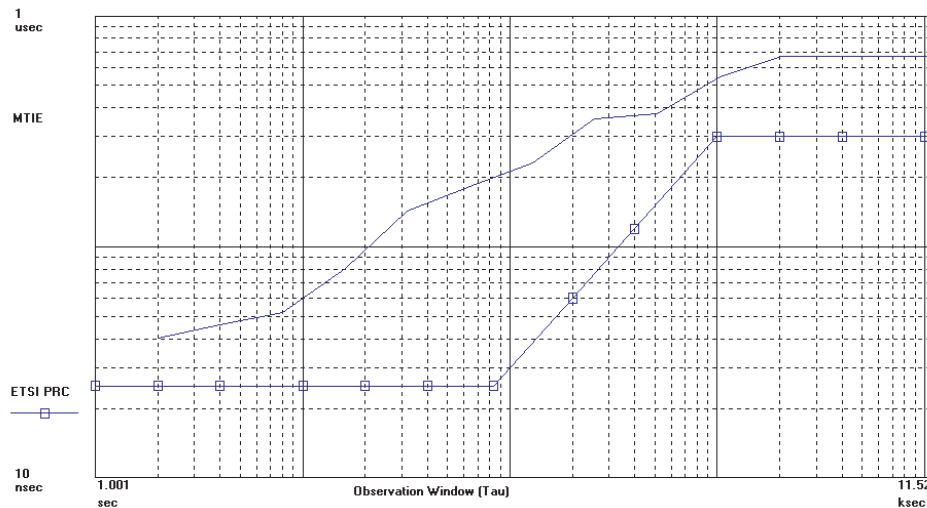

CW46-RS232 CABLE DIAGRAM

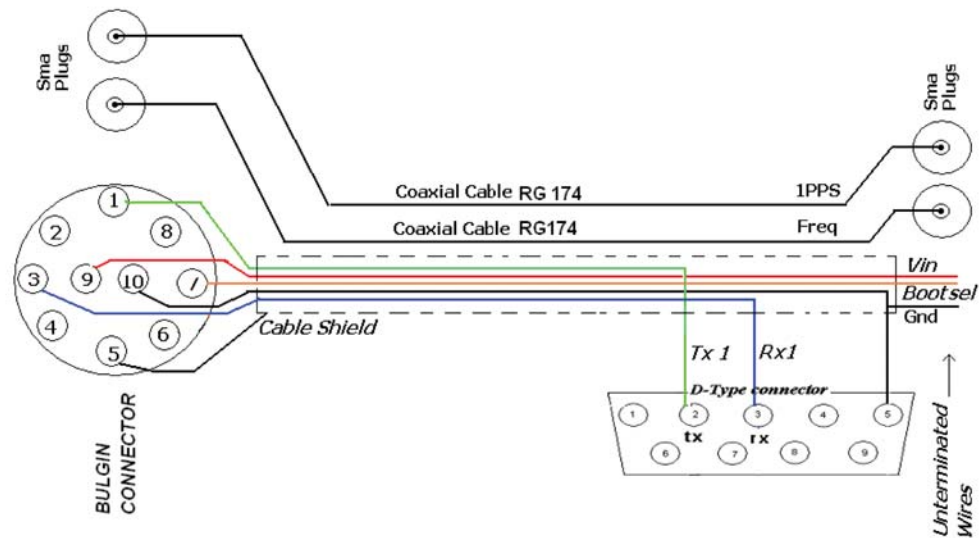

Pin	Name	I/O	Description
1	TXD	O	NMEA 0183 output from GPS Core, Refer to CW25 User Manual for description of proprietary messages. The Baud rate is up to 38400 and the default is 38400.
3	RXD	I	NMEA 0183 input to GPS Core. Refer to CW25 User Manual for description for proprietary commands.
5	GND	PWR	Cable shield GND.
7	BOOTSEL	I	Boot Select pin allows Firmware to be upgraded when pulled low (i.e. tie to Gnd Wire before power-up).
9	VCC	PWR	Voltage Supply Input. 5V - 18V DC to be supplied here.
10	GND	PWR	Power supply return to ground.
SMA 1	1PPS	O	1 Pulse Per Second output. Pulse is 100uS in duration and rising edge signifies top of second
SMA 2	FREQ_OUT	O	Programmable synchronized frequency output from GPS core, this frequency is 10MHz by default, but may be changed by sending a NMEA command. The period of the output frequency must be a multiple of 100ns. See CW25 User Manual for details.

CW46-RS232 CABLE OVERVIEW & SETUP INSTRUCTIONS

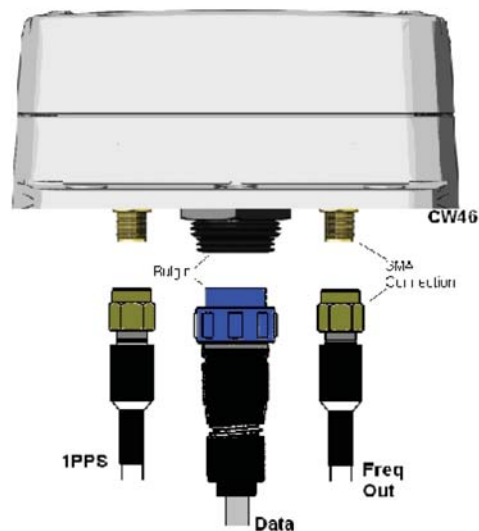

Setup Instructions

Place the CW46 where it has a good view of the sky.

1. Attach Bulgin Data Connector to CW46.
2. Connect RS232 Socket to PC.
3. Apply Power Supply Voltage between the Red (+ive) and Black (-ive) unterminated wires.
4. Data should start to stream.
5. Wait for GPS lock.
6. Once GPS lock is achieved, the 10MHz output frequency and the 1PPS signals will become available from the SMA connections on the underside of the CW46 unit. The SMA cables, that were received with the unit, should be attached to these.



CW46 GPS Sensor

NavSync Ltd. Headquarters

*Bay 143
Shannon Industrial Estate
Shannon, Co. Clare, Ireland
Phone: +353 61 475 666
E-mail: sales@navsync.com*

In North America

*2111 Comprehensive Drive
Aurora, IL 60505, USA
Phone: 630.236.3026
E-mail: northamerica@navsync.com
www.navsync.com*